

# JBC

[www.jbctools.com](http://www.jbctools.com)



## Guide sets for SF280

Ref. GSF08V/GSF10V/GSF15V/  
GSF05/GSF08/GSF10/GSF15

# Guide Set for SF280 with V-Cut



## Packing List

### GSF08V - Ø 0.8 mm

Includes:

0018630	Guide tube .....	1 unit
0018632	Input nozzle .....	1 unit
0018637	Guide wheel .....	1 unit
0018638	Blade clamp .....	1 unit
0018635	Blade .....	1 unit
0019818	Manual .....	1 unit

### GSF10V - Ø 1 mm

Includes:

0019168	Guide tube .....	1 unit
0019170	Input nozzle .....	1 unit
0019172	Guide wheel .....	1 unit
0018638	Blade clamp .....	1 unit
0018635	Blade .....	1 unit
0019818	Manual .....	1 unit

### GSF15V - Ø 1.5 mm

Includes:

0019169	Guide tube .....	1 unit
0019093	Input nozzle .....	1 unit
0019296	Guide wheel .....	1 unit
0018638	Blade clamp .....	1 unit
0018635	Blade .....	1 unit
0019818	Manual .....	1 unit

**Guide Set for SF280 without V-Cut****Packing List****GSF05 - Ø 0.5 mm**

Includes:

0019521	Guide tube .....	1 unit
0019520	Input nozzle .....	1 unit
0019519	Traction wheel .....	1 unit
0019479	Counting wheel .....	1 unit
0019818	Manual .....	1 unit

**GSF08 - Ø 0.8 mm**

Includes:

0018630	Guide tube .....	1 unit
0018632	Input nozzle .....	1 unit
0019480	Traction wheel .....	1 unit
0019479	Counting wheel .....	1 unit
0019818	Manual .....	1 unit

**GSF10 - Ø 1 mm**

Includes:

0019168	Guide tube .....	1 unit
0019170	Input nozzle .....	1 unit
0019480	Traction wheel .....	1 unit
0019479	Counting wheel .....	1 unit
0019818	Manual .....	1 unit

**GSF15 - Ø 1.5 mm**

Includes:

0019169	Guide tube .....	1 unit
0019171	Input nozzle .....	1 unit
0019481	Traction wheel .....	1 unit
0019479	Counting wheel .....	1 unit
0019818	Manual .....	1 unit

## Changing the drag wheels and the blade

For this operation, disconnect the unit.

1. Use the allen key and the spanner to loosen the screws.



2. Replace the wheel, the blade clamp and the blade with the new ones.

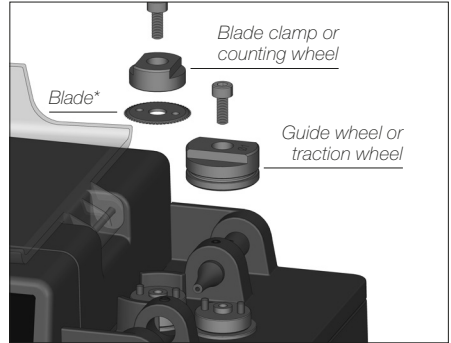

 \* Handle with care to avoid any cuts with the blade because it is sharp.

## Replacing the guide tube

For this operation, disconnect the tool from the control unit.

1. Open the guide clamp, take off the guide tube and insert the new one.

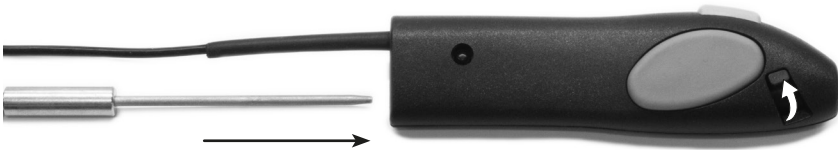

2. You can easily adjust the length of the tube by opening the guide clamp.



## Tool assembly

Connect the tool to the control unit.

1. Push the guide tube to the end and tighten the screw.
2. Connect the jack.

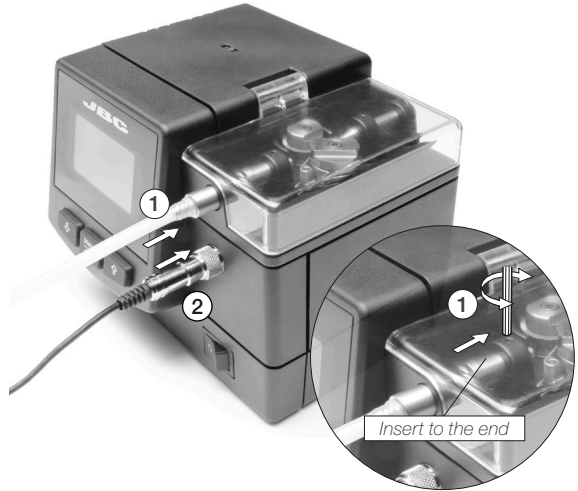

## Load the solder wire

1. Use the lock rings to prevent the reel from sliding on the bar.
2. Feed the wire into the input nozzle (2) until it reaches the wheels.

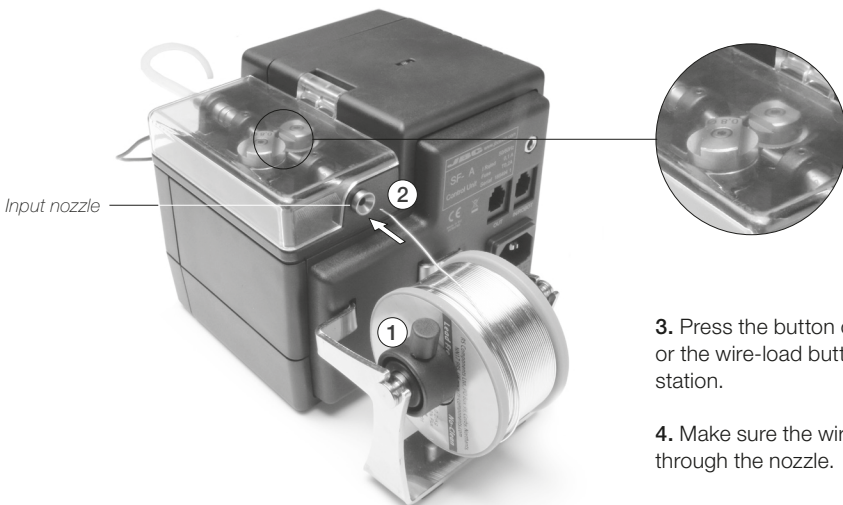

3. Press the button on the tool or the wire-load button on the station.

4. Make sure the wire passes through the nozzle.





# Specifications

- GSF08V** - Ø 0.8 mm with V-Cut
- GSF10V** - Ø 1 mm with V-Cut
- GSF15V** - Ø 1.5 mm with V-Cut
- GSF05** - Ø 0.5 mm without V-Cut
- GSF08** - Ø 0.8 mm without V-Cut
- GSF10** - Ø 1 mm without V-Cut
- GSF15** - Ø 1.5 mm without V-Cut

- Weight: 102 gr (0.01 lb)
- Guide tube length: 126 cm (49.6 in)

Complies with CE standards  
ESD protected

# JBC

## Warranty

JBC's 2 year warranty covers this equipment against all manufacturing defects, including the replacement of defective parts and labour. Warranty does not cover product wear or misuse. In order for the warranty to be valid, equipment must be returned, postage paid, to the dealer where it was purchased.



This product should not be thrown in the garbage. In accordance with the European directive 2002/96/EC, electronic equipment at the end of their life must be collected and returned to an authorized recycling facility.



Manual in other languages available on our website

**[www.jbctools.com](http://www.jbctools.com)**